

PRODUCT INFORMATION PACKET

Model No: 445THFN9037
Catalog No: W613
150,1800,TEFC,445T,3/60/575
Severe Duty



Regal and Marathon are trademarks of Regal Beloit Corporation or one of its affiliated companies.
©2018 Regal Beloit Corporation, All Rights Reserved. MC017097E





Nameplate Specifications

Output HP	150 Hp	Output KW	112.0 kW
Frequency	60 Hz	Voltage	575 V
Current	138.0 A	Speed	1785 rpm
Service Factor	1.15	Phase	3
Efficiency	95.8 %	Duty	Continuous
Insulation Class	F	Design Code	B
KVA Code	G	Frame	445T
Enclosure	Totally Enclosed Fan Cooled	Overload Protector	No
Ambient Temperature	40 °C	Drive End Bearing Size	6318
Opp Drive End Bearing Size	6316	UL	Recognized
CSA	Y	CE	Y
IP Code	56		

Technical Specifications

Electrical Type	Squirrel Cage Inverter Rated	Starting Method	Line Or Inverter
Poles	4	Rotation	Reversible
Mounting	Rigid base	Motor Orientation	Horizontal
Drive End Bearing	Ball	Opp Drive End Bearing	Ball
Frame Material	Cast Iron	Shaft Type	T
Overall Length	43.35 in	Frame Length	20.25 in
Shaft Diameter	3.375 in	Shaft Extension	8.76 in
Assembly/Box Mounting	F1/F2 Capable		
Outline Drawing	B-SS517026-2025	Connection Diagram	A-EE7300U

This is an uncontrolled document once printed or downloaded and is subject to change without notice. Date Created: 06/29/2018

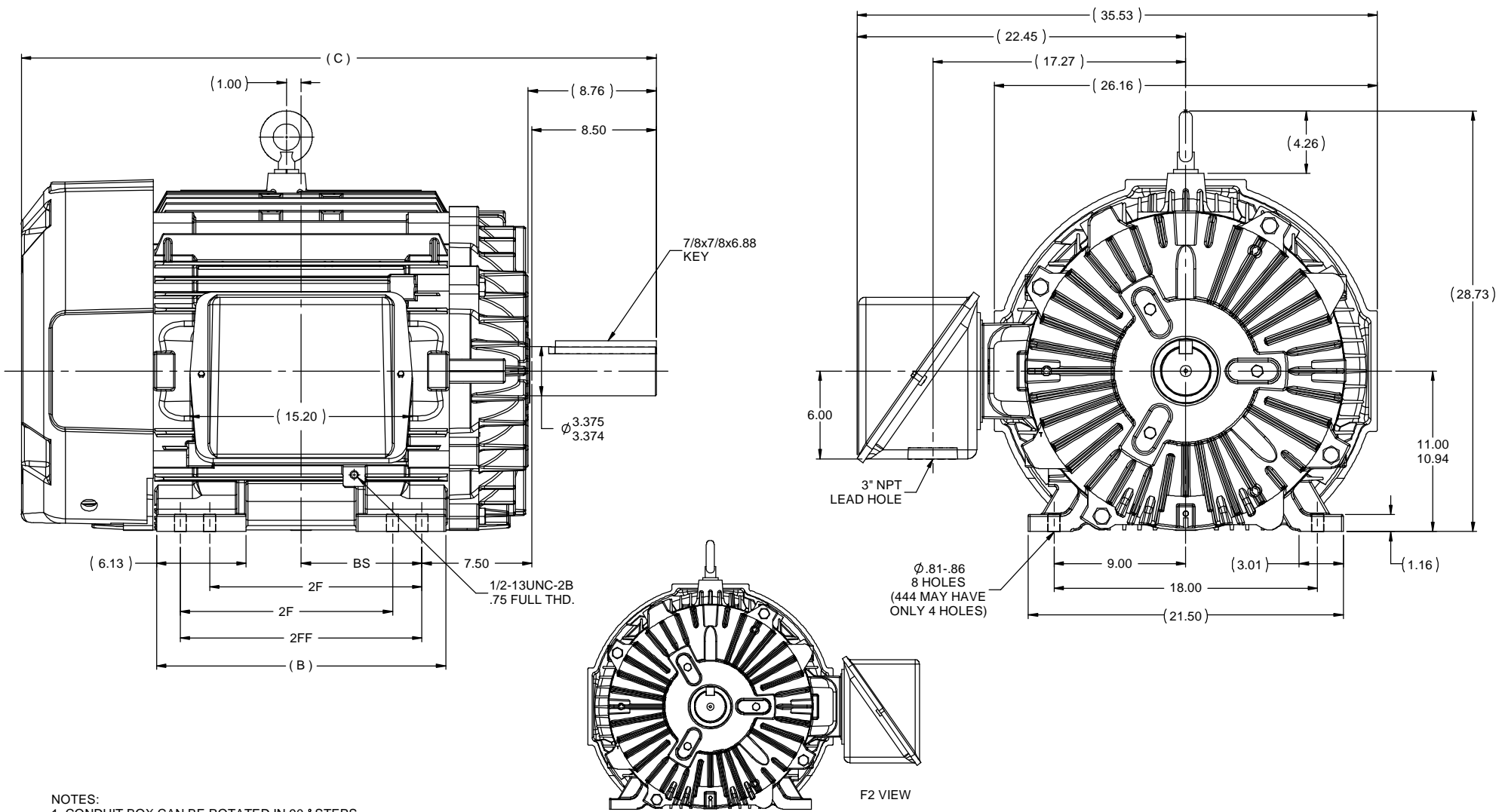

- NOTES:
 1. CONDUIT BOX CAN BE ROTATED IN 90 ° STEPS.
 2. CONDUIT BOX CAN BE MOUNTED ON OPPOSITE SIDE BY REMOVING BRACKETS AND TURNING FRAME 180 °
 3. NAMPLATES TO BE READ FROM CONDUIT BOX SIDE OF MOTOR.

8	UPDATED MOUNTING HOLE NOTE	HV 08-07-2012	EH	TOLERANCES UNLESS SPECIFIED		DRAWN DRS 2/24/1999
8	UPDATED FRAME TO CURRENT STD'S. ISAAC 09-5049	JJB 01-17-2012	DEC	INCHES		CHK ML 2/25/1999
7	ADDED F2 VIEW	MSG 04-21-2010	MSG	x ±.1	APPR JL 2/25/1999	SCALE 5:32
6	REVISED FRAME AND DASH TABLE ISAAC09-5049	TJW 04-01-2010	EH	xx ±.02	TITLE OUTLINE	REF
5	UPDATED DRAWING	RJW 04-18-2007	ML	xxx ±.005	444/445T FR. - TEFC - STD	FMF
4	CHG TO SHORT FAN GUARD DESIGN PER CN39335	RWR 02-17-2007	ML	xxxx ±.0005	MATL	PAGE OF
NO	REVISION	BY & DATE	CHK	LANG ±7'30"	FINISH	REV
THIRD ANGLE PROJECTION				RFP	PREV	SIZE DRAWING NO
				NETWORK FILE NAME	SS517026	REV
				SIZE	B	DRAWING NO
				SS517026		REV
						9

IF MOTOR HAS 9 LEADS



IF MOTOR HAS 6 LEADS



A-9806 DECAL IF CALLED FOR

IF MOTOR HAS 12 LEADS



VIEW OF TERMINAL END

DRAWING REVISION L	REVISION BY AJW	DATE 05-04-2015	TOLERANCES UNLESS OTHERWISE SPECIFIED:	DRAWN BY DRS	Regal Beloit America, Inc.																					
ECO ECO-0077067	APPROVED BY EWH	DATE 05-05-2015	<table style="font-size: small; border-collapse: collapse;"> <tr> <td><u>DEC.</u></td> <td><u>INCH</u></td> <td><u>mm</u></td> <td><u>ANGLE</u></td> </tr> <tr> <td>.X</td> <td>±0.1</td> <td>[±2.5]</td> <td>±7' 30"</td> </tr> <tr> <td>.XX</td> <td>±0.02</td> <td>[±0.51]</td> <td></td> </tr> <tr> <td>.XXX</td> <td>±0.005</td> <td>[±0.127]</td> <td></td> </tr> <tr> <td>.XXXX</td> <td>±0.0005</td> <td>[±0.0127]</td> <td></td> </tr> </table>	<u>DEC.</u>			<u>INCH</u>	<u>mm</u>	<u>ANGLE</u>	.X	±0.1	[±2.5]	±7' 30"	.XX	±0.02	[±0.51]		.XXX	±0.005	[±0.127]		.XXXX	±0.0005	[±0.0127]		DATE 09-27-1996
<u>DEC.</u>	<u>INCH</u>	<u>mm</u>	<u>ANGLE</u>																							
.X	±0.1	[±2.5]	±7' 30"																							
.XX	±0.02	[±0.51]																								
.XXX	±0.005	[±0.127]																								
.XXXX	±0.0005	[±0.0127]																								
ECO DESCRIPTION UPDATED TO SOLIDWORKS <small>COPYRIGHT REGAL BELOIT AMERICA, INC. ALL RIGHTS RESERVED. PROPRIETARY AND CONFIDENTIAL INFORMATION - THIS DOCUMENT IS THE PROPERTY OF REGAL BELOIT AMERICA, INC. ("OWNER") AND CONTAINS OWNER'S PROPRIETARY INFORMATION. ANY PERSON, CORPORATION OR OTHER FIRM RECEIVING IT IS DEEMED, BY RECEIVING IT, TO AGREE THAT IT, AND/OR ANY PART OF IT, SHALL NOT BE DISCLOSED TO ANY PERSON, CORPORATION OR OTHER ENTITY, DUPLICATED, AND/OR USED, EXCEPT AS EXPRESSLY APPROVED IN WRITING IN ADVANCE BY OWNER. THIS DOCUMENT SHALL BE RETURNED TO OWNER UPON REQUEST. IT MAY BE SUBJECT TO CERTAIN RESTRICTIONS UNDER APPLICABLE EXPORT CONTROL LAWS AND REGULATIONS.</small>			APPROVED BY GK	MATERIAL	PROCESS/FINISH																					
			REMOVE BURRS & BREAK SHARP EDGES: .003/.015 [.076/.381] X 45° CORNER FILLETS: R.02 [.51] MACHINED SURFACES: 200 $\sqrt{\text{INCH}}$ 5.1 $\sqrt{\text{mm}}$ mm SHOWN IN [BRACKETS]			DATE 09-30-1996	EE7300U																			
REFERENCE	THIRD ANGLE PROJECTION	SIZE A				DRAWING NUMBER			SHEET 1 OF 1																	

Data Sheet

Date: 19-06-2017
 Customer: _____
 Attention: _____
 Submitted by: FAREEDA DUDEKULA



445THFN9037

Submittal

Data @ 575 V

Motor Load Data

Load	0%	25%	50%	75%	100%	115%	125%	LR
Current (Amps)	48.0	57.6	80.0	108	138	156	170	868
Torque (ft-lb)	0.00	110	220	330	441	508	553	800
RPM	1800	1796	1792	1790	1785	1,782	1780	0
Efficiency (%)		93.0	95.4	96.2	95.8	95.8	95.4	
P.F. (%)	4.5	53.0	74.0	82.0	85.0	86.0	86.0	28.0

Motor Speed Data

	LR	Pull-Up	BD	Rated	Idle
Speed (RPM)	0	900	1725	1785	1800
Current (Amps)	868	760	480	138	48.0
Torque (ft-lb)	800	775	1,150	441	0.00

Information Block

HP	150.0			
Sync. RPM	1800			
Frame	445			
Enclosure	TEFC			
Construction	TFN			
Voltage	575 V			
Frequency	60 Hz			
Design	A			
LR Code letter	G			
Service Factor	1.15			
Temp Rise @ FL	70 ° C			
Duty	CONT			
Ambient	40 ° C			
Elevation	1,000 feet			
Rotor/Shaft wk ²	47.0 Lb-Ft ²			
Ref Wdg	T4454127 NONE			
Sound Pressure @ 1M	75 dBA			
VFD Rating	CONSTANT 2:1			
Outline Dwg	B-SS517026-2025			
Conn. Diag	A-EE7300U			
Additional Specifications:				
0				
365THFS8036				
EQUIV CKT (OHMS / PHASE)				
R1	R2	X1	X2	Xm
0.0320	0.0190	0.2630	0.2480	6.8900

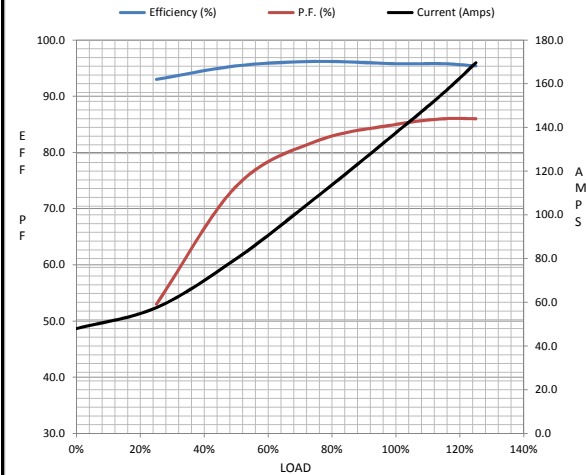

Speed -Torque Curve

